

# CARBON FOOTING SYMMETRIC

Slatnar d.o.o. | Ulica Ignaca Borštnika 16, 4207 Cerklje na Gorenjskem, Slovenia  
T: (+386) 40 978 373



## 1 PLACE CARBON ON THE SHOE

- Check carbon placement for proper fit
- If carbon sticks out from laces part, mark excess with white marker
- Cut off marked excess
- Ensure carbon matches shoe

We use a Dremel rotary tool with a diamond cutting disc.



## 2 DRILL BIT M3.5

Make holes into carbon and shoes with drill bit size **M3.5**

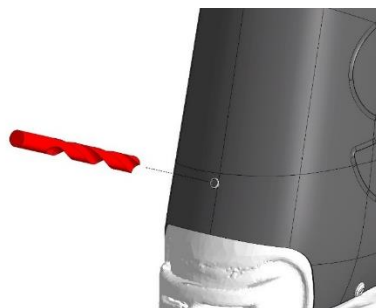

## 3 THREADED DRILL M4

Make holes into carbon and shoes with threaded drill size **M4**

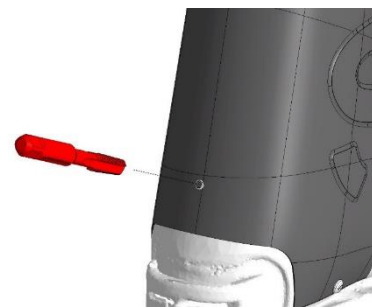

## 4 SCREWS TX20 – M4x8

Fasten carbon with screws TX20 – **M4x8**

